

Increased Stability  
and Lighter Weight

# R1 COMPRESSOR™ FOR COLD CLIMATE HEAT PUMP



The new type of compressor  
that combines high-  
efficiency scroll and simple  
structure of the rotary.



**LG Electronics Component Solutions**

4300 North Point Pkwy, Alpharetta, GA 30022

**For more information**

Visit <https://www.lg.com/global/business/compressor-motor>

E-mail [lg.compressors@lge.com](mailto:lg.compressors@lge.com)

For continual product development, LG reserves the right to change the specifications without notice.  
Copyright © 2023 LG Electronics Inc. All Rights Reserved.



# R1 Compressor™ Highlight

## Why LG R1 Compressor™?

Featuring groundbreaking efficiency that combines the technology of a conventional scroll and rotary compressor, the R1 Scroll Compressor performs up to 10% better than our conventional scroll compressors. With the motor positioned at the top of the unit and the scroll at the center, the R1's simplified structure leads to significant sound reduction. The R1 Compressor operates across variable speeds, unlocking optimal temperature and humidity control of the conditioned space. With increased stability and lighter weight the R1 is ideal for residential and commercial applications, having been tested in harsh environments to ensure durability.



## Features and Benefits



### High Compression Ratio

The new R1 Compressor delivers 20% higher compression ratio compare to conventional model, providing better heating performance.



### Wide Operating Envelope

Flash gas injection extend the compressor's operating envelope, improving heating capacity.



### Optimized for Heatpump Applications

R1 is a great choice for various heatpump application operating in extreme cold weather.

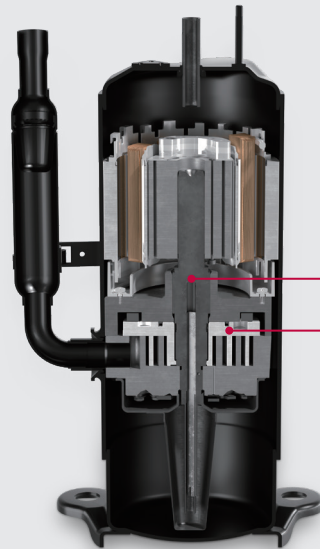

### Shaft-Through Structure

With increased stability the R1 features a shaft that runs through the compressor, controlling the orbit with less impact and unleveling. Compared to conventional scroll designs with cantilevered mechanicals, better stability contributes to quieter operation and increased efficiency.



### Groundbreaking Design

With the motor positioned at the top of the unit and the scroll located in the center, the R1 represents a combination of technologies found in conventional scroll and rotary compressors.

## Specifications

LG R1 Compressor™	
Refrigerant	R32
Model	RJA036MAB
Type	Variable Speed
Displacement [cm <sup>3</sup> / rev]	31.6
Operation Speed [rps]	15-120
Frequency [Hz]	Inverter
Phase [Ø]	3
Voltage [V]	DC380V
Cooling Capacity [Btu/hr]	24,100
Input [Watt]	1,040
EER [Btu/W.hr]	23.17

\* Test Condition : Cond. / Evap. Temperature( 100°F / 50°F ) @ 30rps

## Operating Envelope

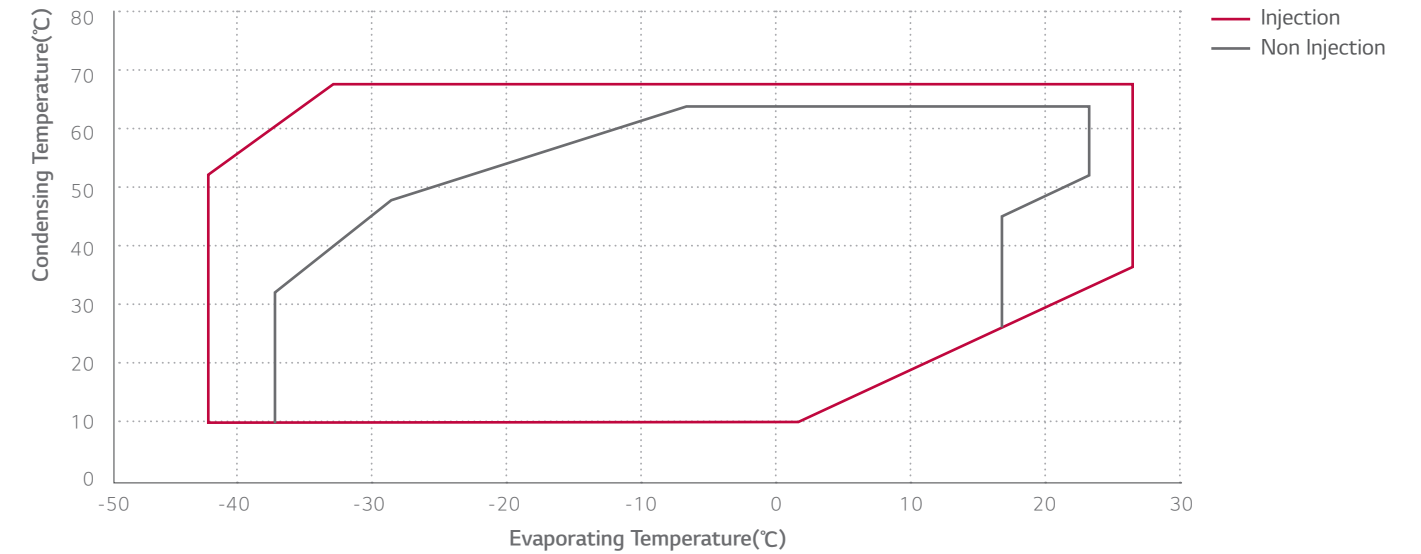

## Dimensions

(unit : mm)

ID Ø 12.75 - 12.85 ID Ø 19.10 - 19.20

